



**Joinery
Products**

XL Joinery Ltd
La Porte Vista
Folding Sliding Doors
Specification, Warranty and Instructions

LA PORTE VISTA 6'

LA PORTE VISTA 8'

XL Joinery Ltd
Bradford Road, Batley, West Yorkshire,
England
WF17 8NE
Tel: 01924 350500
Fax: 01924 350525
www.xljoinery.co.uk

LA PORTE VISTA DOORS

Product Specification

The XL Joinery La Porte Vista Folding Sliding Doorsets have been designed to provide an ideal combination of performance and aesthetics. They are available in Pre-finished Oak and Prefinished White options. A matching timber frame and Aluminium/ Timber Sill are supplied as standard.

Door Design:

- 54mm thick doors.
- FSC engineered timber construction.
- Factory Glazed 24mm Toughened Double Glazed Units with Low-E glass and Argon gas fill.
- Available in Pre-finished Oak or Prefinished White with matching frame.
- Brio Weatherfold Summit Satin Stainless Sliding Folding Door Gear.
- 3 point Multi Point Locking System, Top and Bottom Flush Bolts and Keeps, Weather Seals (in brown), and Frame Assembly Screws.
- External Aluminium Sill with internal timber upstand to match Frame and Doors.
- Doors fold outwards from the building either to the left or right dependent on selected configuration.

Performance:

- Stated U-Values are based upon a 2.0m x 2.0m opening size for the purposes of Part L of the Building Regulations:
 - Softwood White Finished La Porte Vista Doors: **1.6W/m²K**
 - Oak La Porte Vista Doors: **1.8W/m²K**

Guarantees



10 Years Guarantee
against Manufacturing
Defects



10 Year Guarantee against
Double Glazing Unit Failure

Warranty Information

The warranty offered on the XL Joinery La Porte Vista Doorsets is based on the following conditions:

- The product has been installed correctly and has not been inappropriately modified before, during, or after installation.
- The product has been stored and handled in accordance with XL Joinery guidelines.
- The product has not been damaged due to improper storage, installation, use or maintenance.
- The product is fit for its intended use and location, (e.g. not used in maritime locations).
- Suitable ventilation was provided during and after installation to regulate moisture content.
- The paint/ stain finish has not failed due to inadequate maintenance or poor installation.
- The paint/ stain finish has not been exposed to physical or chemical damage, e.g. ladders, cleaning agents etc.
- Unfinished products have been treated in accordance with XL Joinery Finishing Guidelines.

Elevation and Section Details

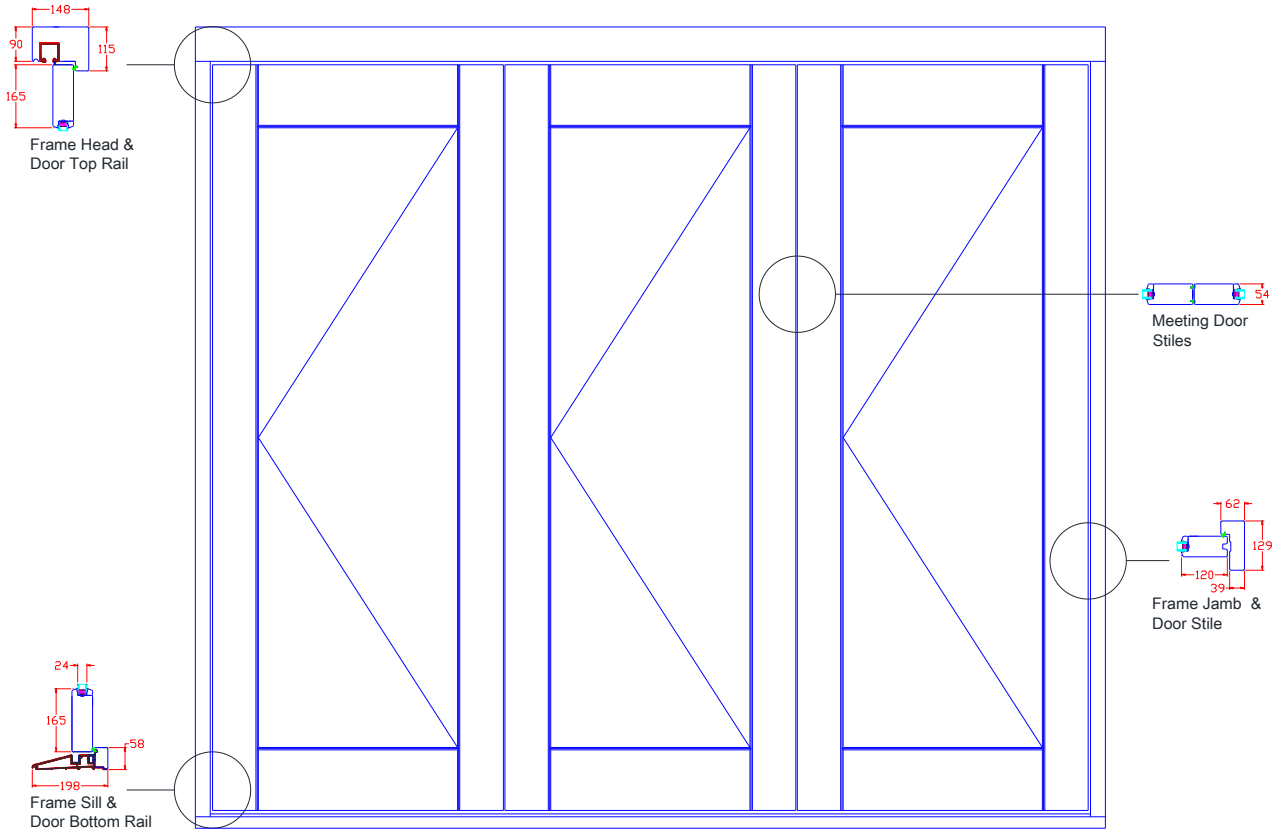

SAFETY IN USE

Glass Caution

Warning! This product contains glass components which, if broken, can cause serious injury. Use extreme caution and keep children away from broken glass.

Tempered Glass Characteristics

Tempered glass is called "safety glass." It is more resistant to breakage than normal float glass and if it is broken, breaks into relatively small, blunt particles, which are less likely to cause injury. It is approximately five times stronger than annealed glass of equal thickness. Greater resistance to thermally induced stress than heat strengthened or annealed glass. Suitable for use as a safety glass. Tempered safety glass is mandated in many window applications and all door applications. Suitable where safety glazing is required, for fire knockout panels, all glass entrances and where extreme wind loads are a concern.

Hardware

Ensure that all fittings function efficiently and are regularly maintained to prevent debris impeding the function of the doors: Failure to do so may result in improper or incomplete functioning of the hardware and potentially restrict the safe operation of the doors.

Fall Prevention

Warning! An open door is a possible fall hazard, particularly when located in an elevated position above ground floor level, e.g. first floor balcony. Where necessary, ensure door openings are protected by suitable guard rails or similar.

LA PORTE VISTA DOORS

Instructions

The XL Joinery La Porte Vista Doorsets are designed and manufactured using cutting edge technology to produce a high performance product. However, the manner in which they are handled, stored, installed and maintained can affect their performance and compromise their service life. Please ensure that you read and understand the following instructions.

STORAGE AND HANDLING

- Check packaging for visible damage on delivery: Inspect the product and notify your merchant immediately if the product is damaged.
- Store the product off the ground on suitable, level bearers.
- Cover the product to avoid damp, dust and other contaminants.
- Storage areas should be well ventilated and not subject to extremes of temperature.
- Avoid **unsuitable** storage such as metal box containers and areas open to the elements. These may be subject to condensation and very high temperatures in direct sunlight. Water can also collect in the protective packaging leading to saturation of some components.
- A building, which has been built or renovated, using processes such as concreting, plastering, rendering, etc., will have a very high humidity level until dried and ventilated. If the product is installed prior to completion of these 'wet' processes, the high residual humidity will force moisture to penetrate the joinery from the inner face thus increasing the moisture content of the timber. Gentle internal heating and good ventilation of the building will greatly reduce the problem.
- Plaster and other building materials can also cause contact damage to protective coatings. If contamination occurs then remove as soon as possible with a solution of mild detergent and rinse with clean water.
- Ensure that any on site assembly or modifications are fully protected. This particularly applies to sill joints, glazing beads and glazing systems. Areas of unprotected end grain exposed by site modifications must be properly sealed and protected by brushing a generous coat of timber end grain sealant onto the exposed area.
- You should take extra care when fitting factory finished products in order to avoid damaging the coating. If you cut or damage the timber when installing the window, it must be treated with a compatible protective treatment.

PAINTING OR STAINING

- **Pre-Finished La Porte Vista Doorsets require regular maintenance as per the MAINTENANCE section of this document.** Periodically check the finishing treatment and touch up as necessary. To ensure the long life and appearance of the La Porte Vista Doorset, retreat every few years.

Unfinished Products

- Before the frame and doors are fitted, all components must be treated in accordance with the finishing instructions.
- All timber surfaces on the frame and doors must be given a total of three coats of high performance wood- stain or paint. It is important to apply the treatment to the doors and frame before they are installed.
- Failure to treat all the timber surfaces before installation may lead to excessive changes in moisture content which will cause the timber to shrink or swell, perhaps causing splits and distortion.
- When applying the stain pay particular attention to sealing the timber end grain on the tops and bottoms of the frame, side and doors and the ends of the sill.
- Also ensure that the lock and hinge cut outs are stained the same as the timber surfaces, and in particular the undersides (unseen faces).
- In areas of severe exposure, external doors should be protected by a canopy or porch in addition to pre-finishing.

NON-FACTORY FINISHED PRODUCT FINISHING SUMMARY

DO

- Use a “High Build” stain or good quality exterior paint
- Apply a minimum of 3 coats to all faces and edges (in severe exposure conditions apply an extra 2-3 coats)
- Apply the same number of coats applied to the face and edges of the door to the top and bottom edges, lock, hinge and letter plate cut-outs
- Apply at least 2 coats immediately upon unpacking the door
- Check that paint or stain manufacturers’ product is suitable for veneered/ engineered doors

DO NOT

- Use thin penetrating seals, oils or stains and hard, brittle paints, varnish or wax
- Apply stains or paints in damp / wet weather
- Use “Low Build” stains or thinned paint
- Mix incompatible products

Note: Cutting, damaging or finishing the product in a manner not detailed in these instructions may invalidate the warranty.

PRODUCT CONTENTS

Check that all the components listed below are present and in good condition prior to assembling the product, (relevant to size option purchased).

FRAME AND DOOR COMPONENTS

LA PORTE VISTA 6’:

Frame Sill x 1

Size: 1787 x 198 x 57mm (maximum dimension)

Frame Head x1

Size: 1787 x 148 x 115mm (maximum dimension)

Frame Jambs x 2 (Left and Right Hand)

Size: 2043 x 129 x 62mm (maximum dimension)

Pivot Door Panel x 1

Size: 1953 x 563 x 54mm

Middle Door Panel x1

Size: 1953 x 563 x 54mm

Locking Door Panel x1

Size: 1953 x 563 x 54mm

LA PORTE VISTA 8’:

Frame Sill x 1

Size: 2384 x 198 x 57mm (maximum dimension)

Frame Head x1

Size: 2384 x 148 x 115mm (maximum dimension)

Frame Jambs x 2 (Left and Right Hand)

Size: 2043 x 129 x 62mm (maximum dimension)

Pivot Door Panel x 1

Size: 1953 x 762 x 54mm

Middle Door Panel x1

Size: 1953 x 762 x 54mm

Locking Door Panel x1

Size: 1953 x 762 x 54mm

HARDWARE COMPONENTS

Sill Component Detail

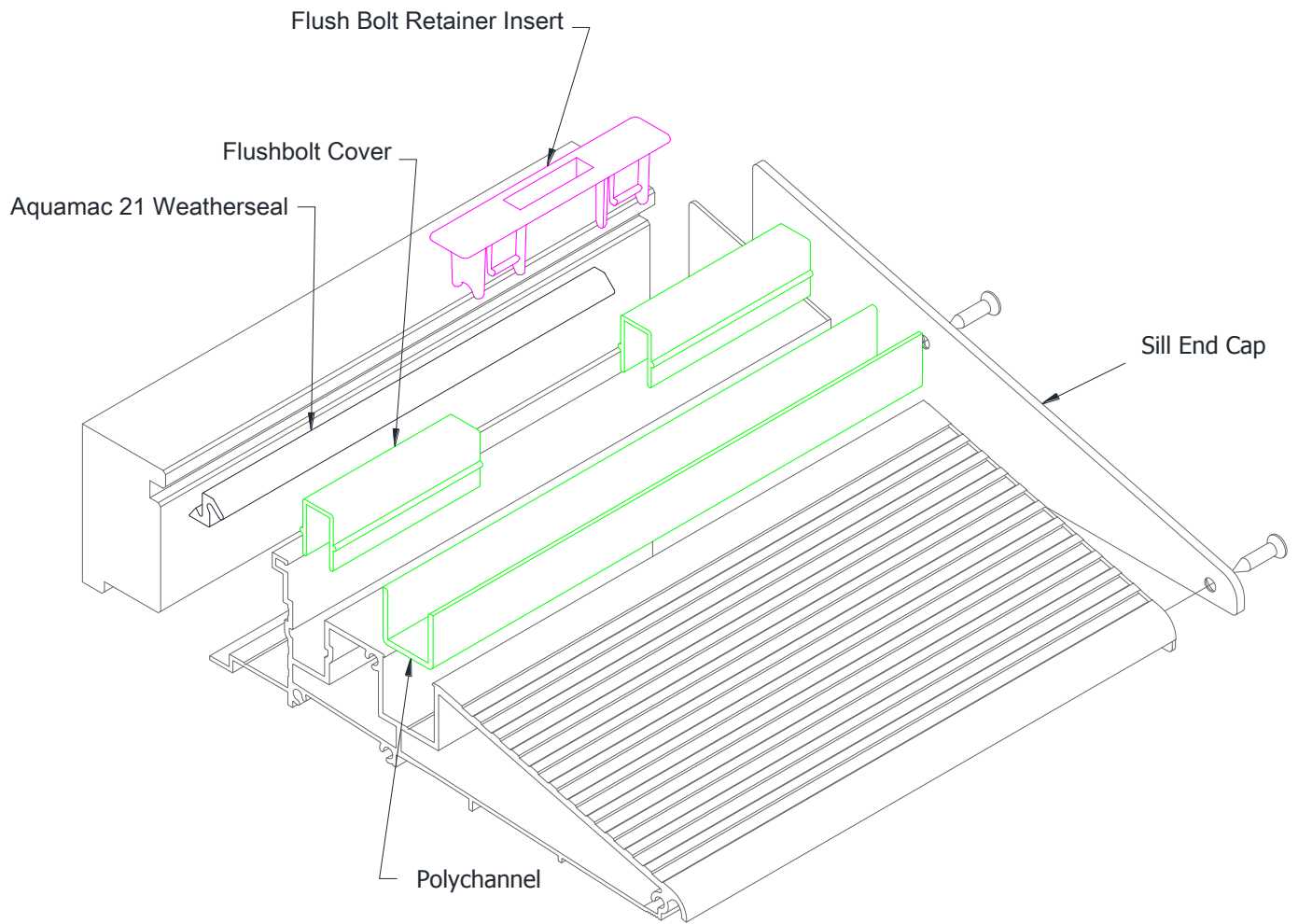

Top Track & Polypile Insert
(Polypile is supplied loose)

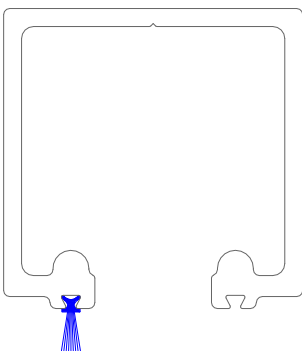

Pivot Set x 1
(BWS1-100H)

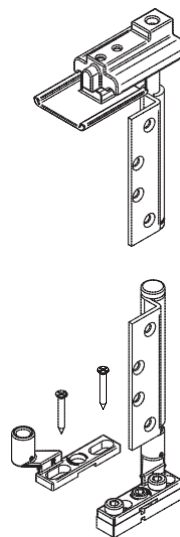

Intermediate Hanger Set x 1
(BWS4-100SHSS)

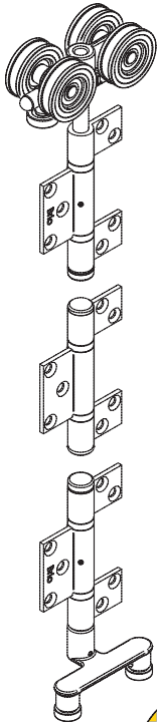

Offset Hinge Set X 1
(BW7-100HSS)

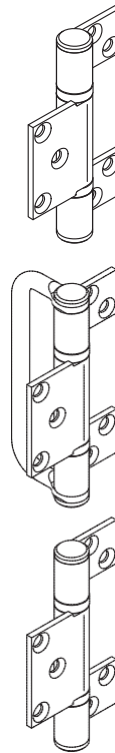

Locking Flush Bolt x 1
(456RESN-1)

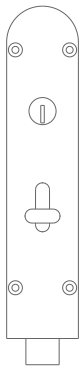

Magnetic Catch Pair x 1
(882 - Optional)

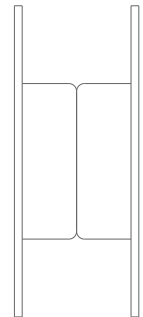
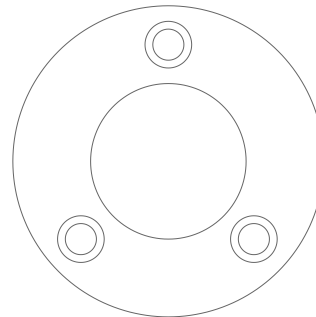

Flush Bolt & Keep x 1
(456RSN-1)

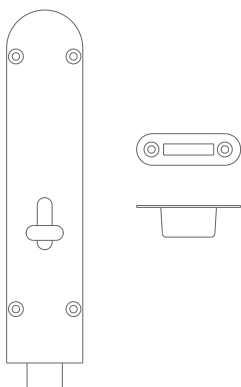

Sill End Caps x 2
(1 Left Hand & 1 Right Hand)

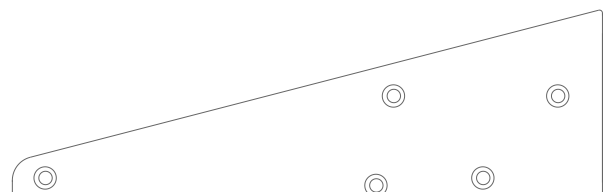

Aquamac 21 Weather Seal:

La Porte Vista 6': 4 x 2m

La Porte Vista 8': 2 x 2m
2 x 2.5m

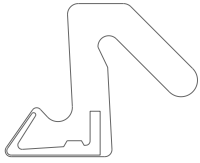

Aquamac 63 Weather Seal:

4 x 2m

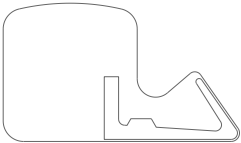

Door Handle Set x 1

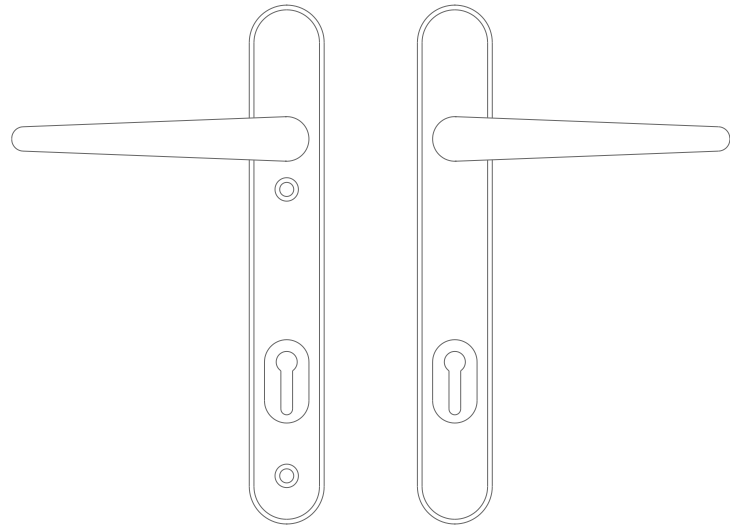

Lock Set x 1

(Including fixing screws)

Multi-Point Lock x 1

One Piece Keep x 1

One Piece Blank Keep x 1

Optional Latch Plate x 1

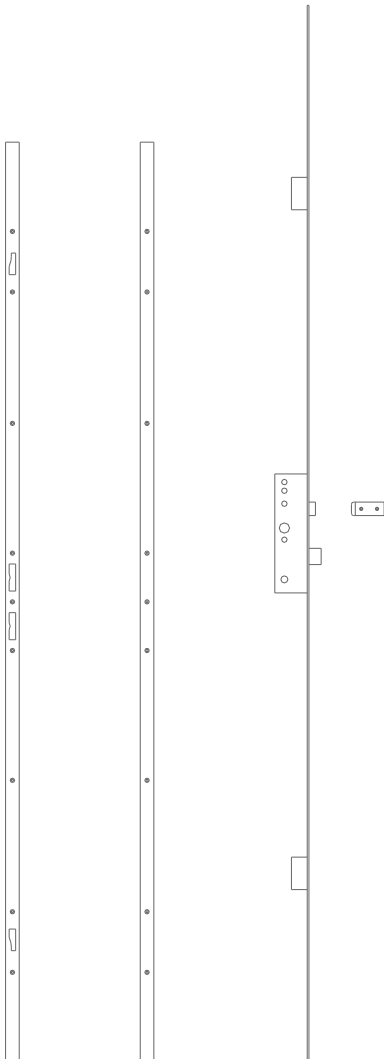

Assembly Screws

Sill Assembly Screws:

2 no 10 x 4"

2 no 10 x 3"

Head Frame Assembly:

2 no 10 x 6"

2 no 10 x 4"

Top Track Fixing Screws:

10 no 6 x 1 1/4"

INSTALLATION

Prepare the Opening.

It is strongly recommended that old doors and windows should not be removed, nor apertures created, until all new materials are on site. This avoids the building being open and insecure for any longer than necessary. **REMEMBER:** Check the product for any damage or missing parts prior to commencing installation.

It is the installer's responsibility to ensure that the door frame is fitted under a suitable lintel or other structural support and that an appropriate damp-proof course/ bedding, is installed at sill level.

The brickwork opening should be approximately 10mm wider than the assembled frame dimensions. Ensure that the brickwork is level and the opening square prior to installing the frame: Failure to do so may result in the frame being out of square which can impede the proper functioning of the doors.

FRAME DIMENSIONS

The **VISTA 6'** external frame dimensions are: 2098mm high x 1787mm wide
Approximate brickwork opening dimensions should be: 2108mm high x 1797mm wide

The **VISTA 8'** external frame dimensions are: 2098mm high x 2384mm wide
Approximate brickwork opening dimensions should be: 2108mm high x 2394mm wide

BRICKWORK OPENING

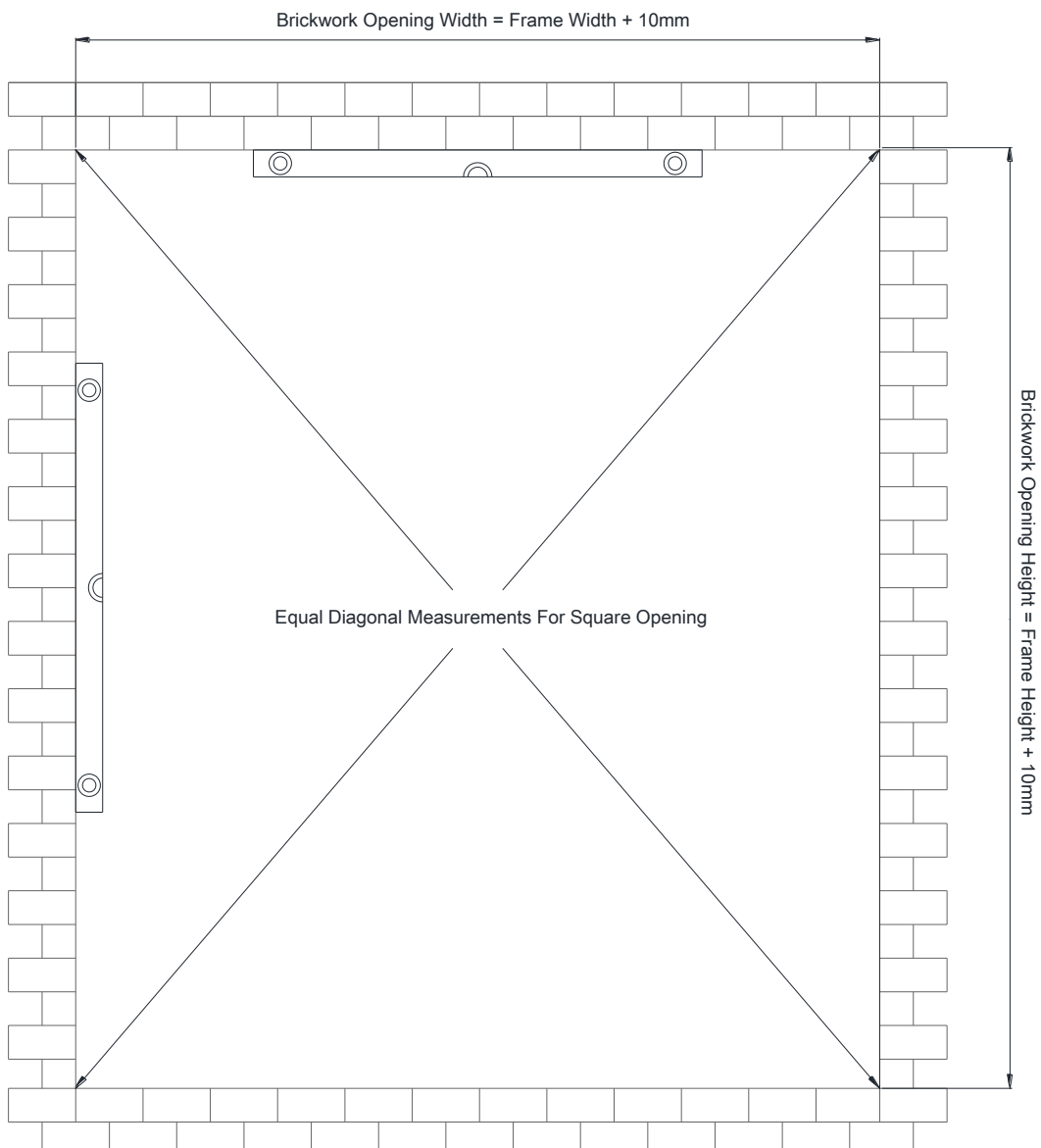

Assemble the Frame

The frame Head and Sill are pre-drilled to accept the screws provided.

- Loose assemble the frame components, ensuring that all joints are tight fitting and flush.
- Apply a waterproof adhesive to the joining surfaces between the Jambs and the Head components prior to screwing the components together.
- Apply a translucent silicone sealant between the Jambs and Sill.
- Use the Assembly Screws to join the Jambs to the Sill and Head components.
- Ensure the frame joints are tight and that the frame is square throughout the installation.
- Wipe off any excess adhesive with a clean cloth.
- Screw the Sill End Caps to the ends of the Sill.

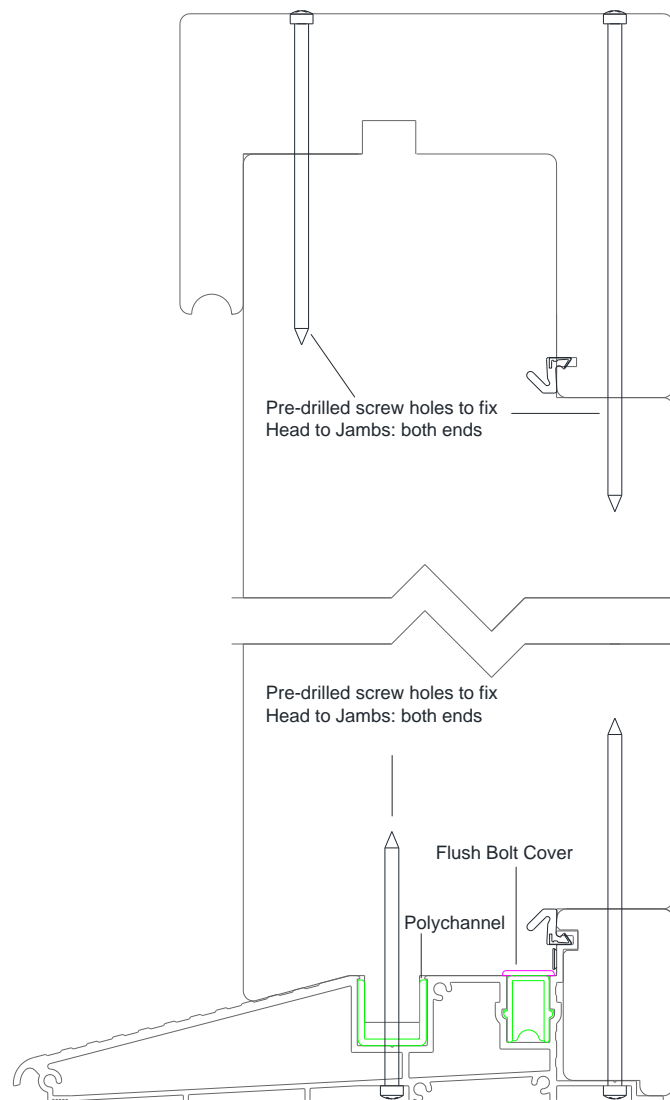

Install the Assembled Frame

- Fit the frame into the brickwork with the sill facing to the outside of the building, ensuring that the frame overhangs the brickwork cavity.
- Situate the Sill on an appropriate damp-proof course/ bedding. Ensure that the sill extends beyond the external face of the brickwork to allow water to drain away freely. Fully Damp Proof Courses should be fitted during construction of the aperture. .
- To reduce the amount of heat lost from the inside of the building to the outside through the frame edges, (Technically known as "a cold bridge"), the frame must be set back to overlap the inner face of the outer brickwork **by at least 30mm**. Adequate insulation should be fitted between the outer and inner wall construction to reduce heat loss around aperture.
- Ensure that the frame is fitted square and level in both the horizontal and vertical plane: Use wooden / plastic packers between the frame and brickwork opening.

- Check that the frame diagonal measurements are equal to ensure that it is square.
- Fit the frame through the Jamb and into the surrounding structure using suitable frame fixings, (not supplied). Drill and countersink the Jamb fixings at 150mm from the top and bottom of the frame with a minimum of five evenly spaced fixings in each of the Jamb.
- Fit the frame through the frame Head and into the lintel using suitable fixings dependent on lintel type.
- When tightening the screws use wooden / plastic packers to prevent the frame from distorting
- If the frame is installed into a timber frame construction, allowance must be made for differential movement between the various construction components.

FIXING THE FRAME

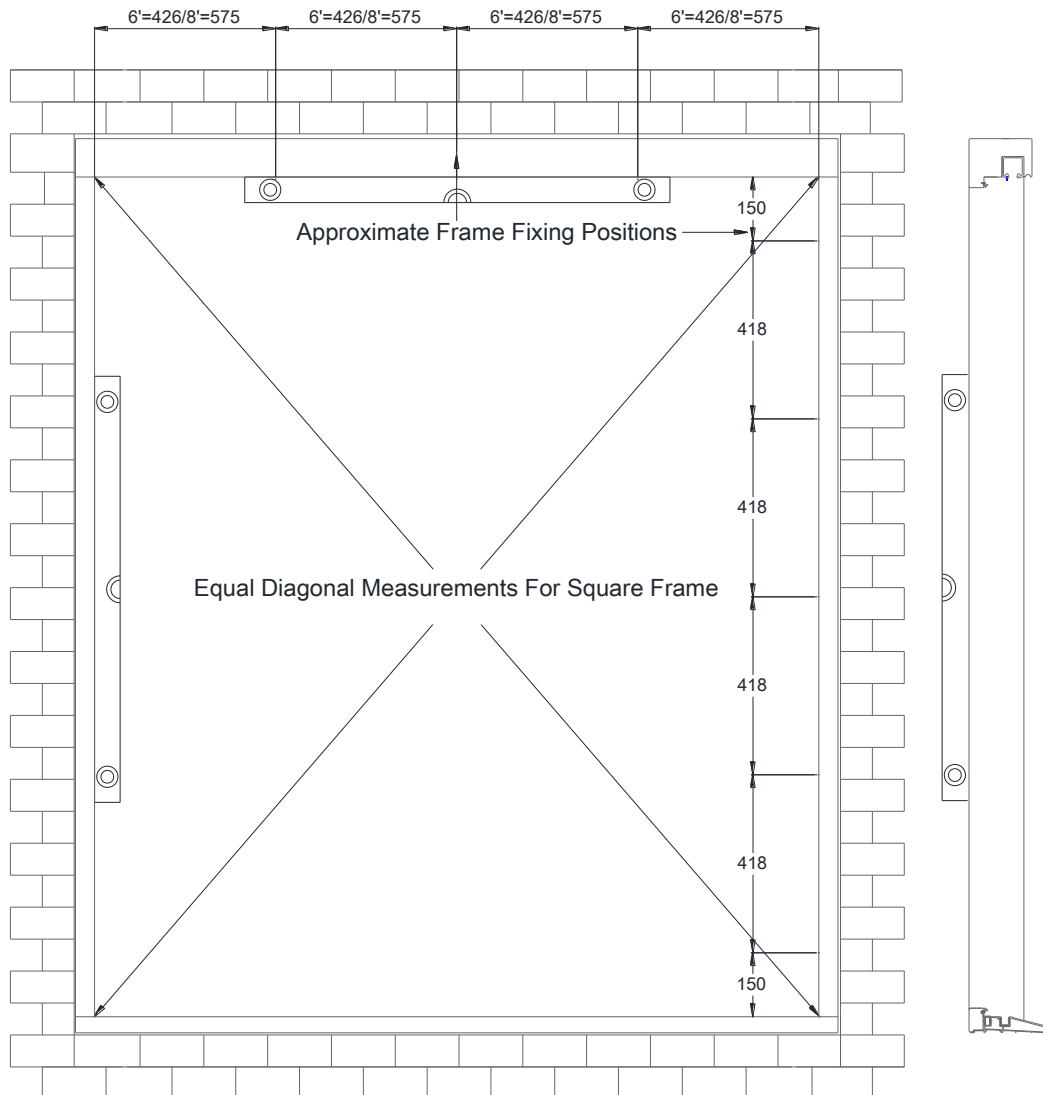

Sealing

To prevent air and moisture passage between the frame and the adjacent wall, the gap should be fully sealed. Various sealing methods can be used, e.g. expanding closed cell foam or a silicone or mastic sealant. If excess sealant spreads over the painted surface, in order to avoid damage, clean it off as soon as possible: Do not allow it to set.

NOTE: It is advised not to fix the frame through the sill as this may damage the sill drainage system: However, if required the sill can be fixed through the deepest part of frame for added stability.

This hardware system is designed to be "Top Hung"; therefore the weight of the doors will be carried by the Top Track. As such it is necessary to ensure that there are secure fixings through the Frame Head into the lintel. Failure to do so may result in the Frame Head bowing which will adversely affect the functioning of the hardware system.

Determine Opening Direction

Decide in what direction the La Porte Vista set needs to open. The set operates as left or right hand opening and the locking door panel will always open outwards from the building. The hardware arrangement will be determined by the opening direction. Follow the instructions for **OPTION A** for Right Hand Opening; or **OPTION B** for Left Hand Opening.

Option A

Inside of Building: Right Hand Opening

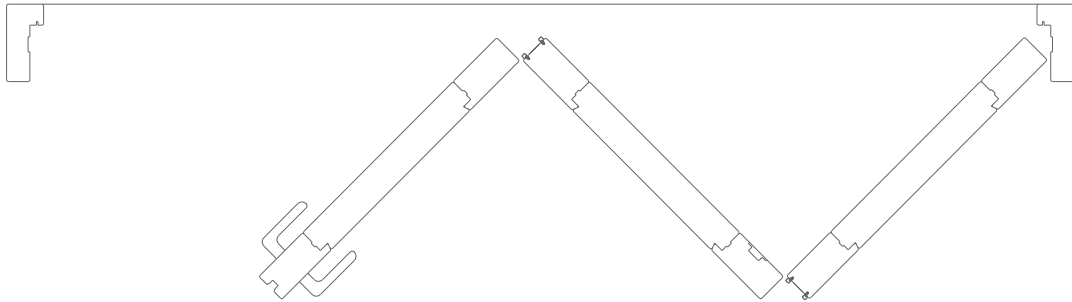

Option B

Inside of Building: Left Hand Opening

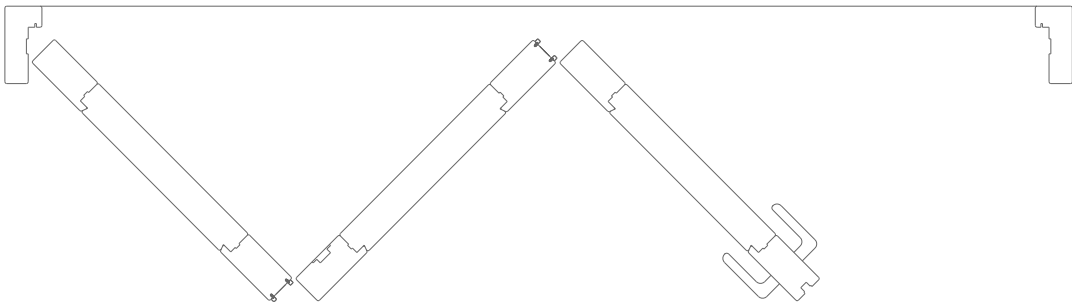

Pre-drill the Hinges

IMPORTANT: Orientate the door panels so that the pinned glazing beads face to the inside of the building once located in the frame. This will ensure that the Low-E glass is situated the correct way around.

- Pre-drill the hinges using a 2.5mm drill bit, ensuring that the hardware configuration matches opening **OPTION A or B** as displayed: Ensure that the holes are drilled into the correct door panels as indicated below. Do not permanently fix the hinges at this stage.
- Ensure that there is a 1mm gap between the hinge barrel and the face of the door panels when locating the hinge pilot holes: This will prevent the door binding after the hinges are fitted.
- The undrilled door panel edges will need pre-drilling during the actual hanging of the door panels.

OPTION A: Right Hand Opening

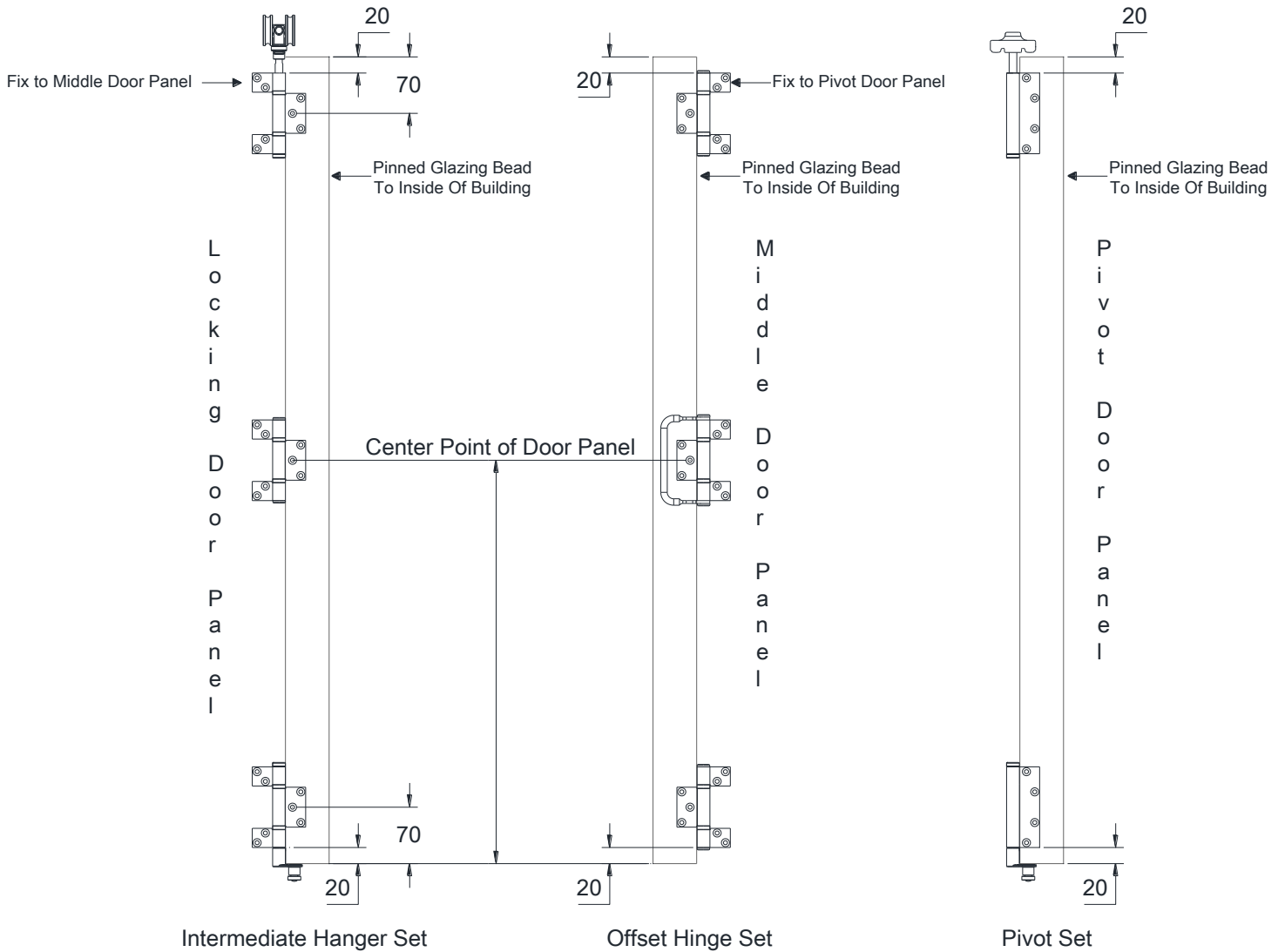

OPTION B: Left Hand Opening

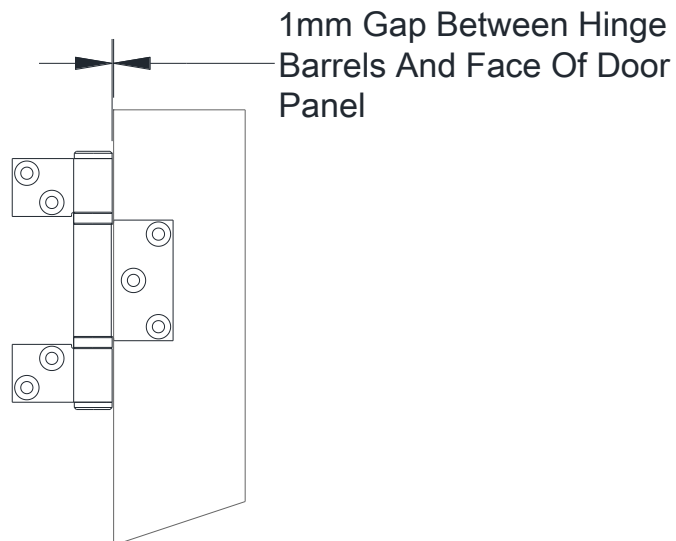
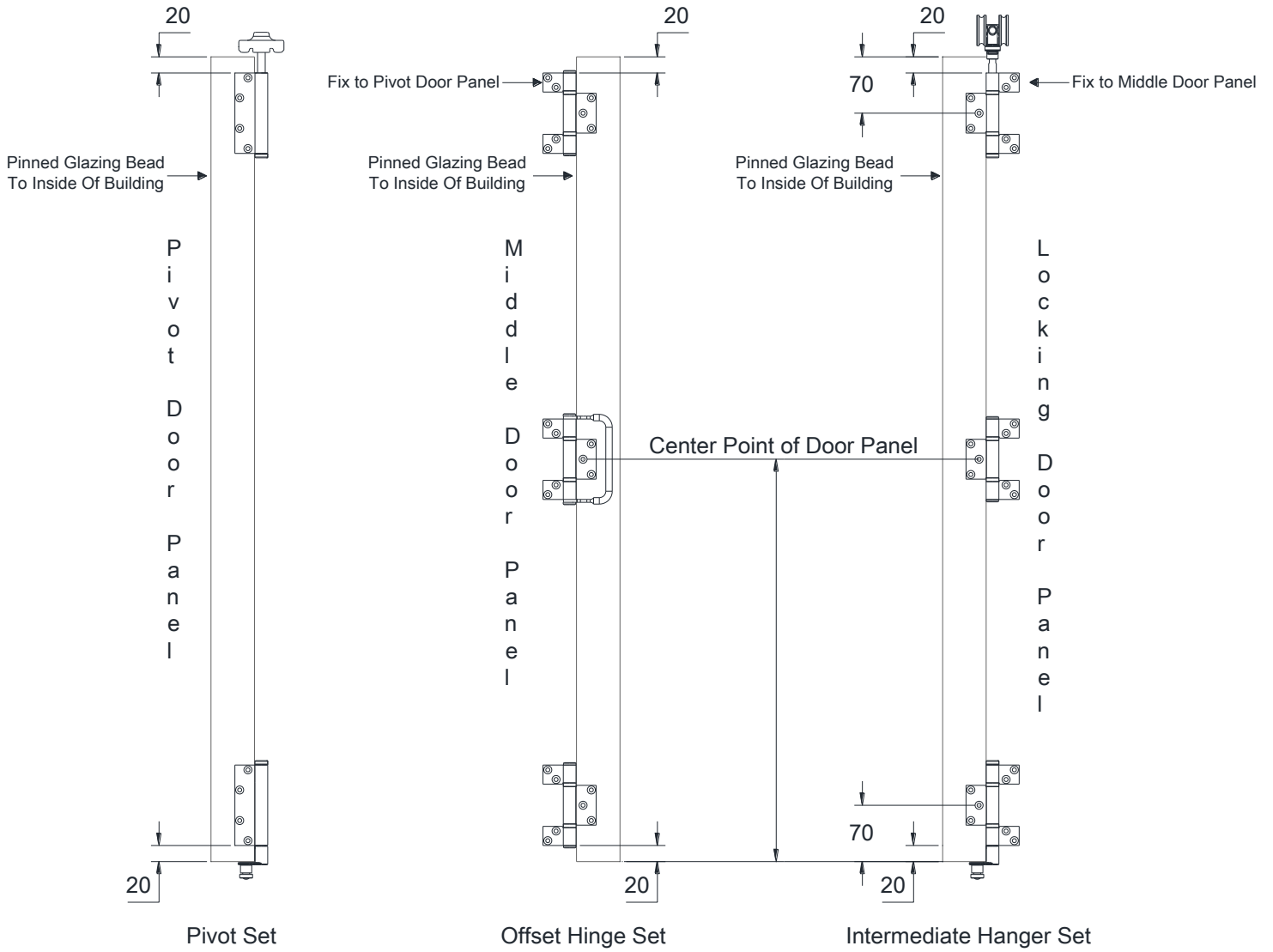

Permanent Fitting of the Top Track

The Top Track will require permanent fixing into the frame Head at regular intervals as displayed below. At this stage the Top Track will have been removed from the Frame Head during the installation of the assembled frame. Drill pilot holes through the Top Track at the designated spacing's. Do not fix the Top Track at this stage.

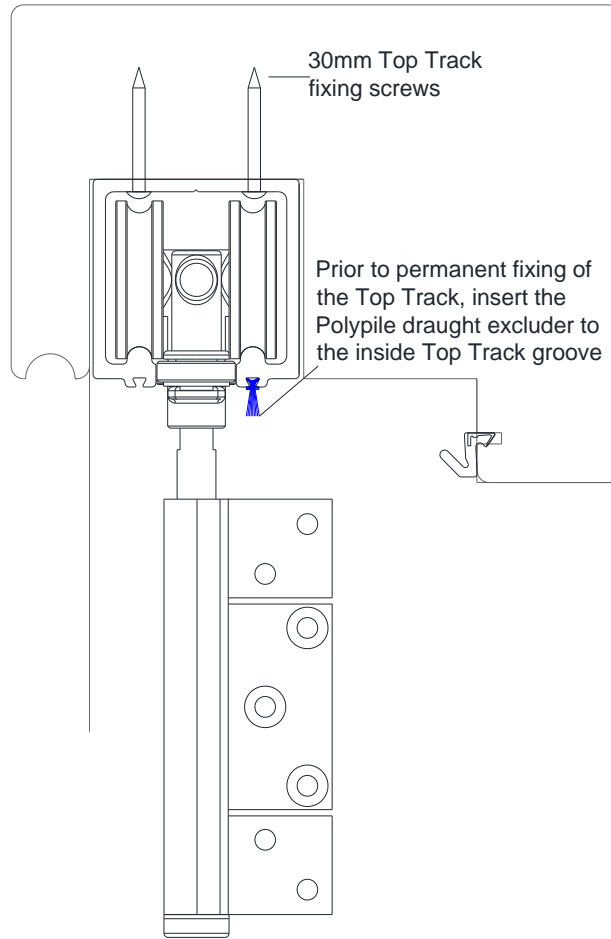

Top Track Fixing Centers

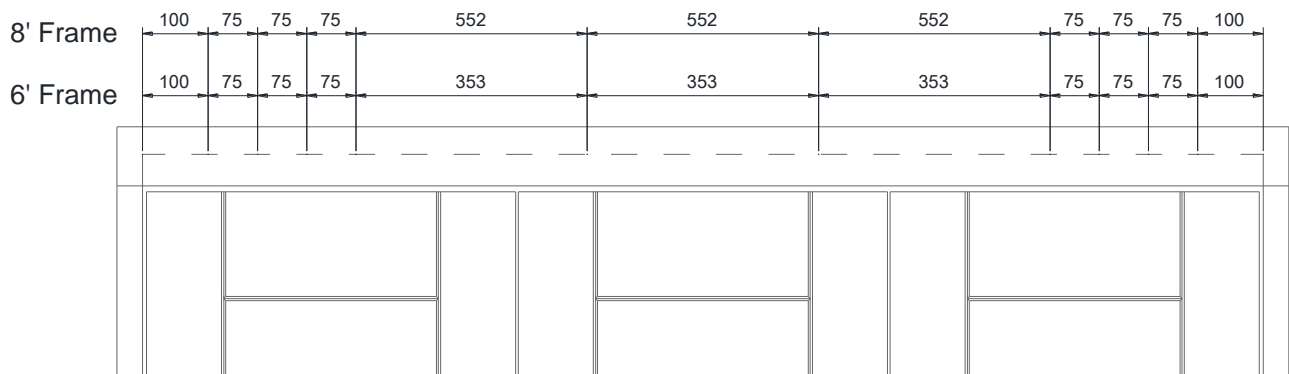

Top Track Assembly

- Prior to fixing the Top Track into the frame Head, insert the Pivot Set and Intermediate Hanger Set into the Top Track in the correct order as displayed in the diagrams below.
- Secure the Top Track into the frame Head with the Top Track fixing screws.
- Position the Pivot block 6mm from the frame Jamb and lock in place with the Clamp Plate and Cap Screws.
- The Pivot Set and Intermediate Hanger Set are dual handed to suit both Left and Right Hand opening options. Therefore the hinge blades may not be in the correct position upon receipt. The hinge blades are rotated as follows:
- Depress the Spring Loaded Adjustment Button and turn the hinge pins anti-clockwise until the hinge blade and pin comes free of the top pivot block and rollers, (Pivot Set and Intermediate Hanger Set respectively)
- Rotate the hinge blade 180 degrees, re-insert the hinge pin through the hinge blade and re-screw the hinge pin into the pivot block and rollers. The Spring Loaded Adjustment Button is also used to adjust the height of the doors after door installation.

Option A: Right Hand Opening as viewed from outside the building

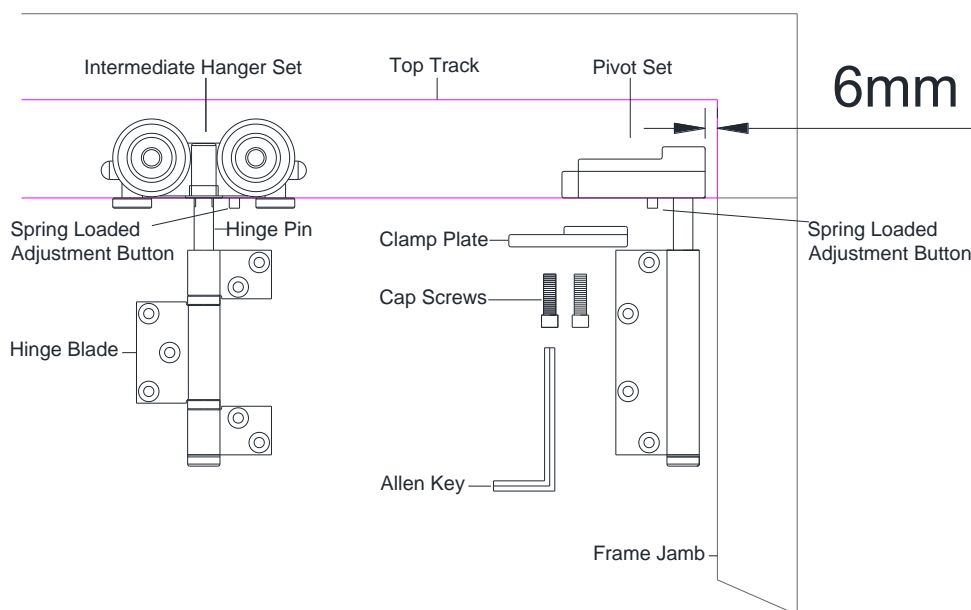

Option B: Left Hand Opening as viewed from outside the building

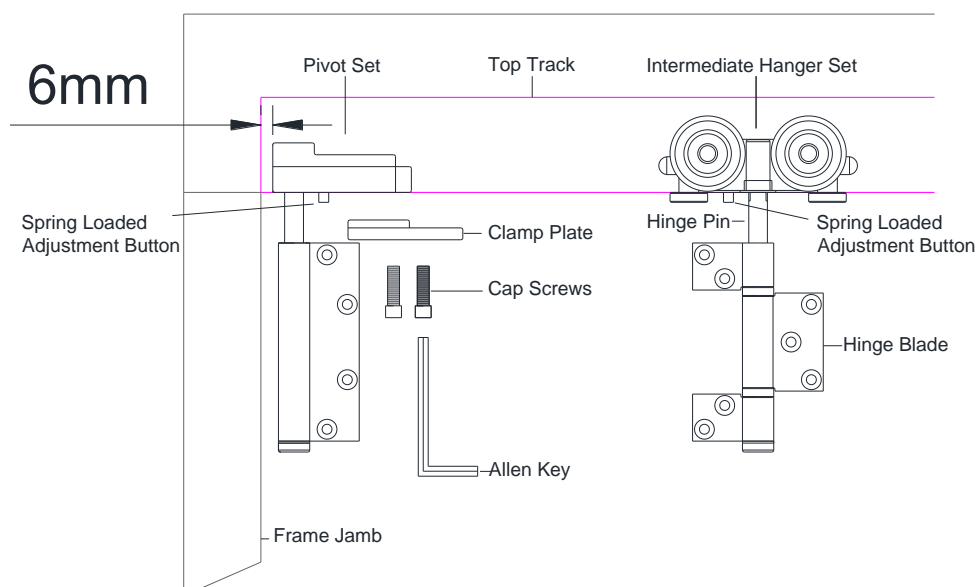

Fit the Bottom Pivot

- The Bottom Pivot comes with a Left and Right Hand guide to suit both opening directions.
- Prior to fixing the Bottom Pivot, select the correctly handed guide arm and secure to the pivot base utilizing the Cap Screws.
- Rotate the hinge blade of the Bottom Pivot to suit door opening direction as displayed below:

Handing the Bottom Pivot as viewed from outside the building.

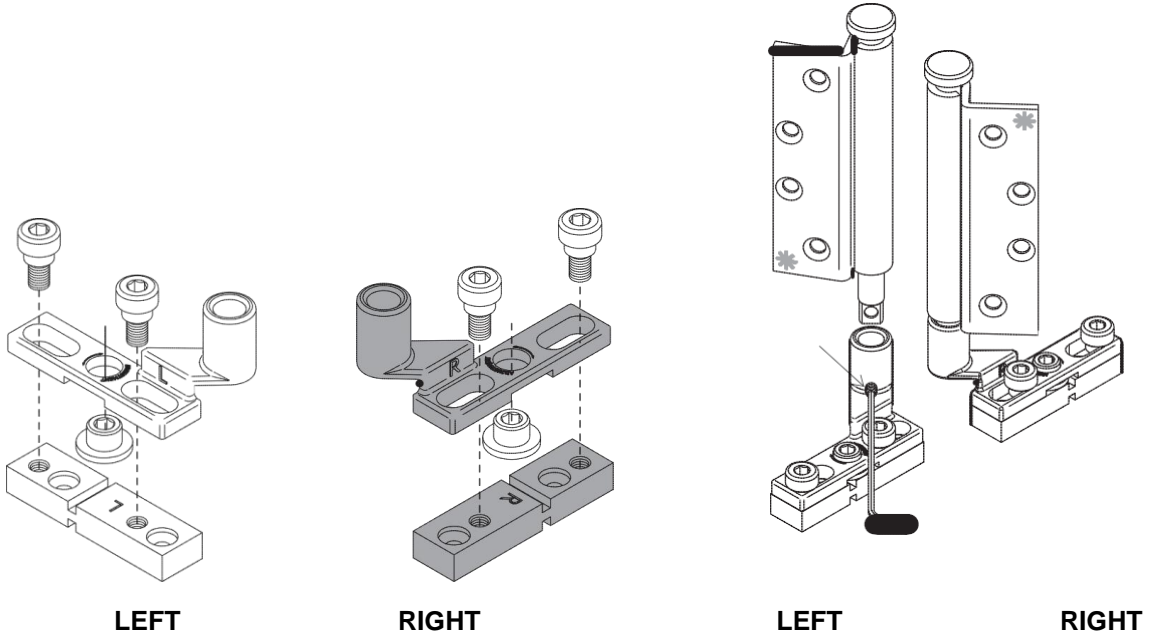

Secure Assembly by tightening Cap Screws

Lock hinge blade with grub screw

- Locate the Bottom Pivot into the Polychannel that is located in the frame Sill 14mm from the frame Jamb and secure with the screws provided.
- When the Cap Screws are loose, the pivot guide can slide freely to adjust the horizontal position of the installed doors.

Left Hand Opening Displayed as viewed from outside the building.

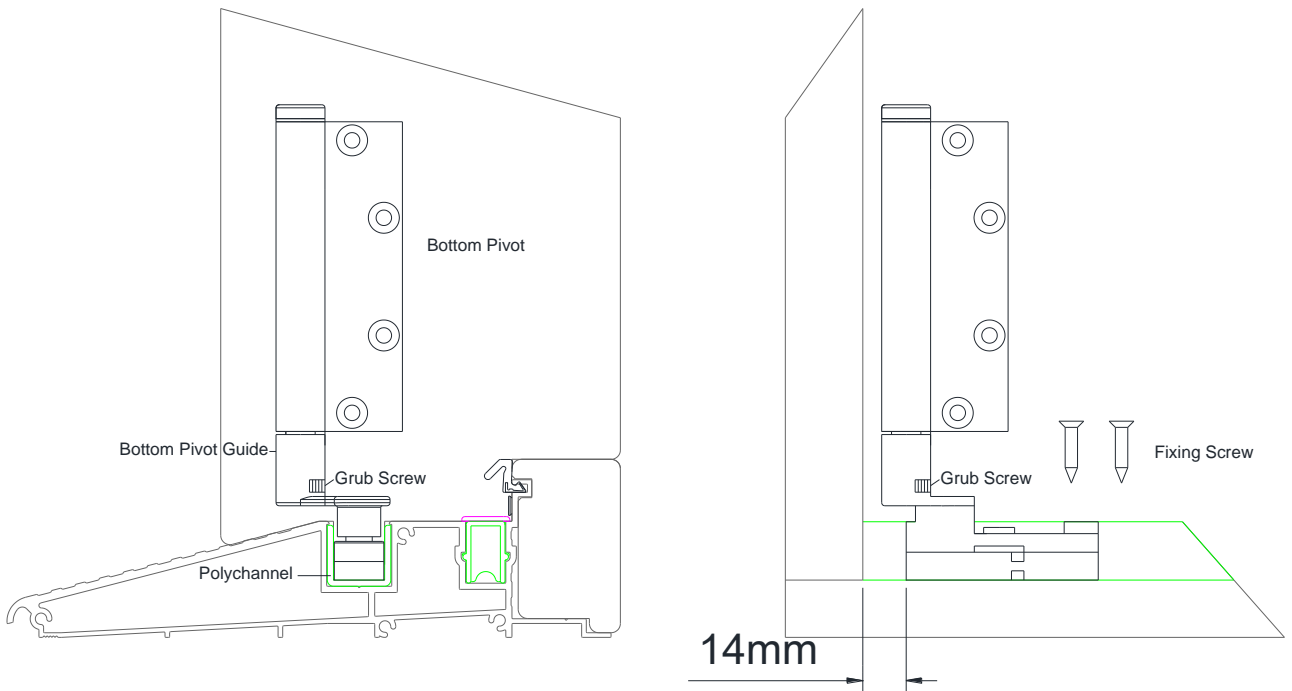

Fit the Pivot Door Panel

NOTE: When fitting all the door panels ensure the hinge blades are located at the correct distances as displayed in the **Pre-drill the Hinges** sections on Pages 12 and 13.

- Fit the Pivot Door Panel by screwing the Pivot Set hinge blades to the door panel through the pre-drilled holes using the screws provided.
- Support the door panel with blocks and wedges to obtain the necessary height for hanging the door.
- Ensure that the pinned glazing beads are facing to the inside of the building.

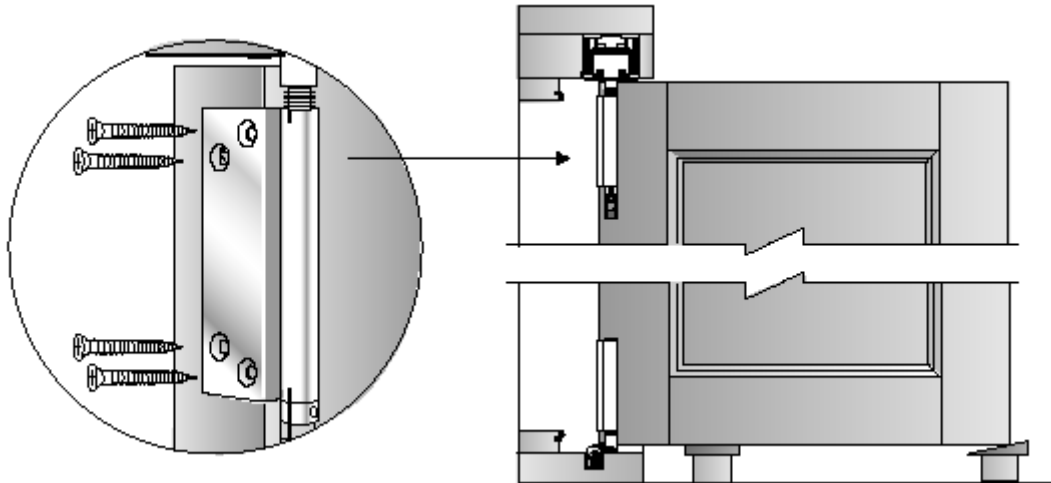

- **IF NECESSARY:** Adjust the door orientation to maintain an even gap between the door panel and the frame jamb:
 - Loosen the Clamp Plate in the Top Pivot Block and slide the block to the left or right. Tighten the Clamp Plate securely after adjustment.
 - Loosen the Cap Screws in the Bottom Pivot Block and slide the block to the left or right. Tighten the Cap Screws securely after adjustment.
 - Ensure that the door panel is plumb after adjustment.

Fit the Middle Door and Locking Door Panels

- Fit the Offset Hinge Set to the Pivot Door Panel, pre-drilling the screw holes and ensuring the handle points to the inside of the building. Remember to leave a 1mm gap between all the hinge barrels and the face of the door.
- Screw the Middle Door Panel to the Half Offset Hinge Set through the pre-drilled holes, again using blocks and wedges to support the door panel.
- Ensure that the pinned glazing beads are facing to the inside of the building.
- Screw the Intermediate Hanger Set to Middle Door Panel, pre-drilling the screw holes and ensuring the Intermediate Hanger Set Guide sits within the frame Sill Polychannel.
- The Intermediate Hanger Set is dual handed to suit both Left and Right Hand opening options; therefore the Bottom Guide hinge blades may not be in the correct position upon receipt. The hinge blades are rotated by loosening the grub screws and rotating the hinge blade:

Guide Security

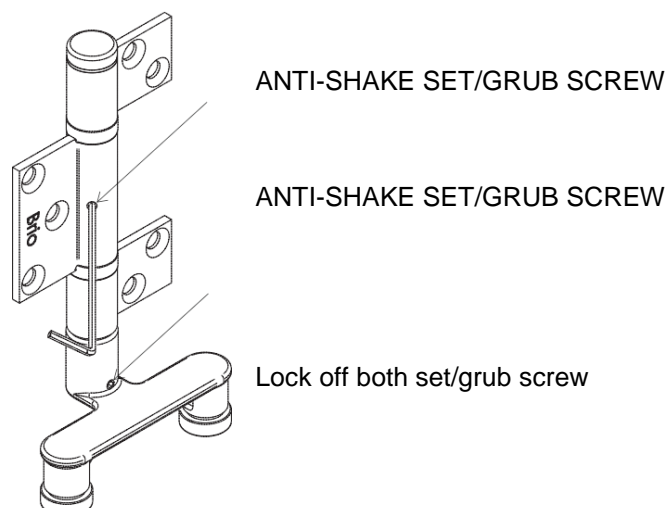

- Screw the Locking Door Panel to the Intermediate Hanger Set through the pre-drilled holes, again using blocks and wedges to support the door panel.
- Ensure that the pinned glazing beads are facing to the inside of the building.
- All doors must line up evenly with each other.

Hardware and Panel Orientation (Left Hand Opening displayed below)

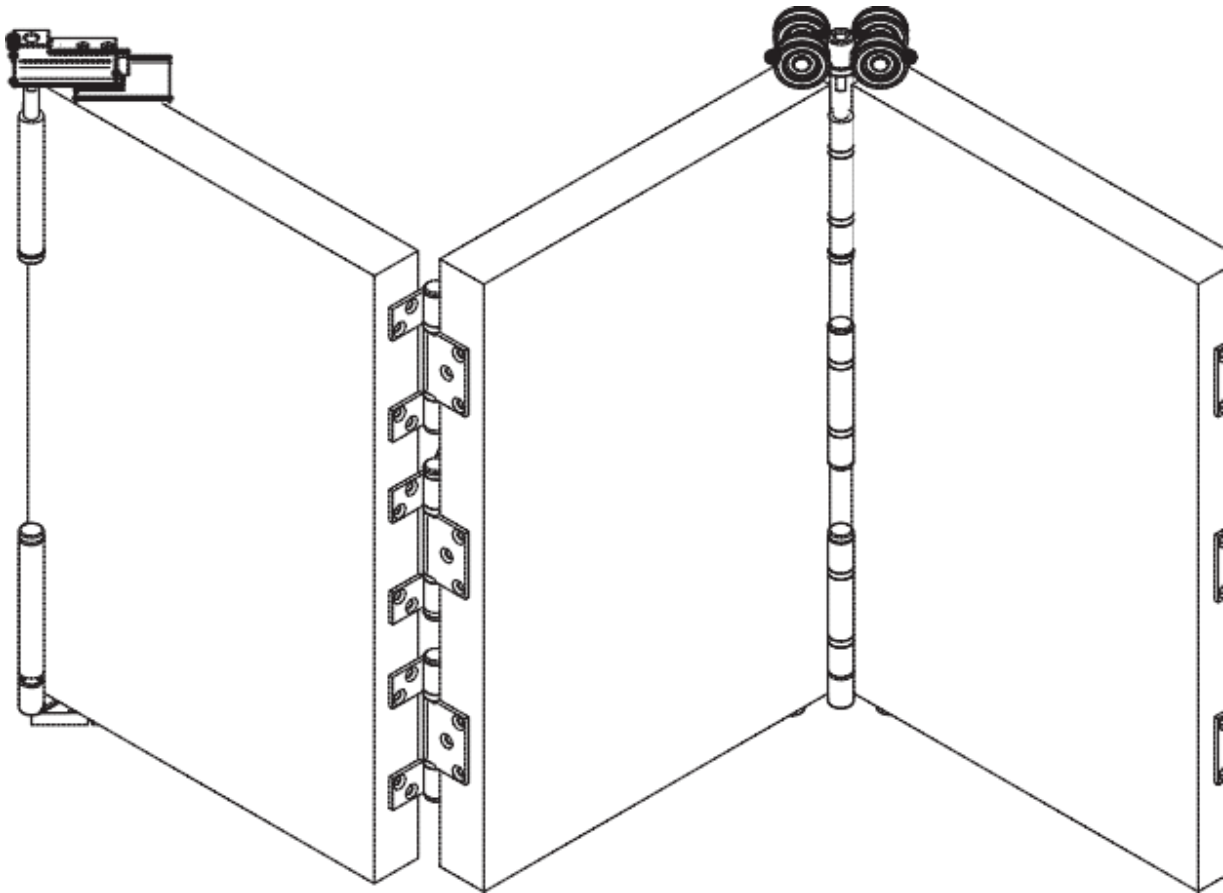
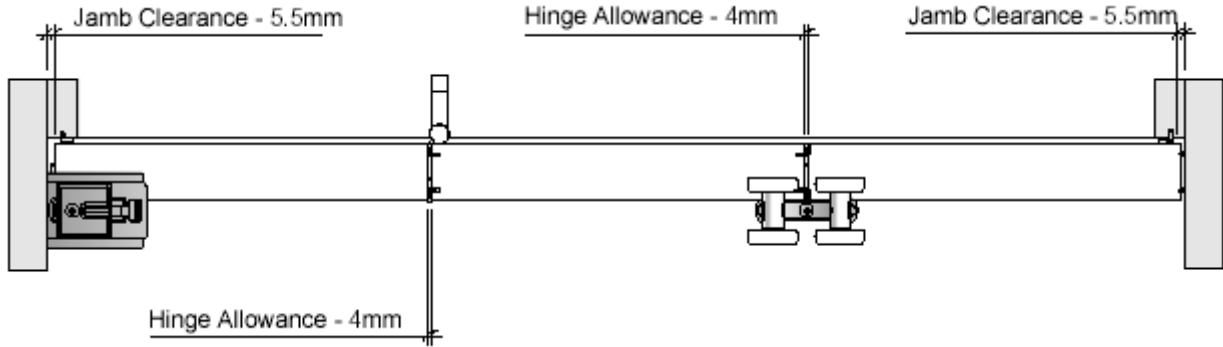

Final Adjustment of the Doors

Further adjustment of the Top Pivot Block and Bottom Pivot can be made to space the door panels correctly across their width.

The height of the door panels can be adjusted by rotating the top hinge pin in the Intermediate Hanger Set and Top Pivot Block. The height should be adjusted so that there is an even 7mm gap between the top of the doors and the underside of the Aluminium Top Track. This is achieved as follows:

- Depress the Spring Loaded Adjustment Button and rotate the hinge pin clockwise or anti-clockwise to adjust the height of the doors.
- When the correct adjustment is achieved, release the Spring Loaded Adjustment Button: A final turn of the hinge pin will automatically lock it in place.

Adjusting the Door Panel Height

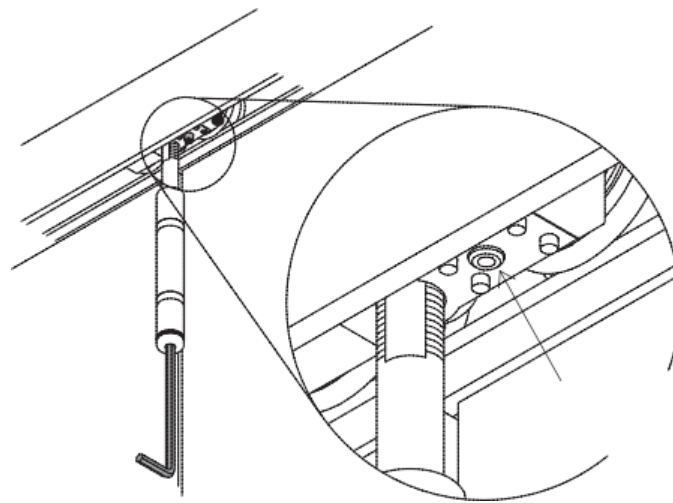

Depress Spring Loaded Adjustment Button

Fit the Weatherseals

Once the doors panels are in position fit the frame and door panel weather seals into the pre-machined grooves as displayed below. Ensure that the Aquamac 21 weather seals are butt jointed in the frame rebate where they meet between the jambs and head/ sill components.

Door Panel and Frame Weatherseals

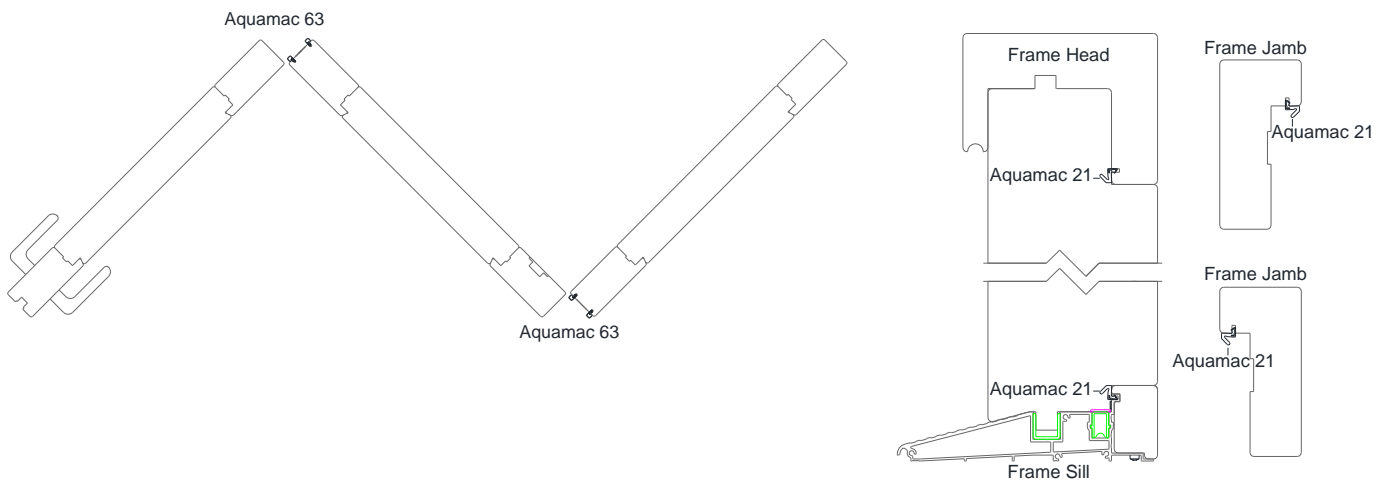

Fit the Door Panel Flush Bolts and Keeps

- The Middle Door Panel is pre-machined to accept the top and bottom Flush Bolts.
- The Locking Flush Bolt is fitted to the bottom of the Middle Door Panel.
- Fix the top and bottom Flush Bolts to the Middle Door Panel. Pre-drill the screw holes prior to fixing the Flush Bolts.
- The frame Head requires drilling and cutting out to accept the top Flush Bolt shoot bolt and Keep: Close the doors to determine the position of the Flush Bolt shoot bolts prior to installing: Ensure that the Final Adjustment of the doors is complete prior to this.
- To facilitate fixing of the Flush Bolt Keep the Aquamac 21 weatherseal can be temporarily removed from the frame Head: Remember to replace the weatherseal after the Keep is fitted.
- It is recommended that the Keep cut out is coated with silicone prior to final fitting of the Flush Bolt Keep to ensure that there is no moisture ingress.
- Insert the Flush Bolt Retainer Insert in the frame Sill groove so that the bottom Flush Bolt shoot bolt engages inside it.
- Cut the plastic Flush Bolt Cover to fit to either side of the Flush Bolt Retainer Insert.

Flush Bolt and Keep Fitting Arrangement

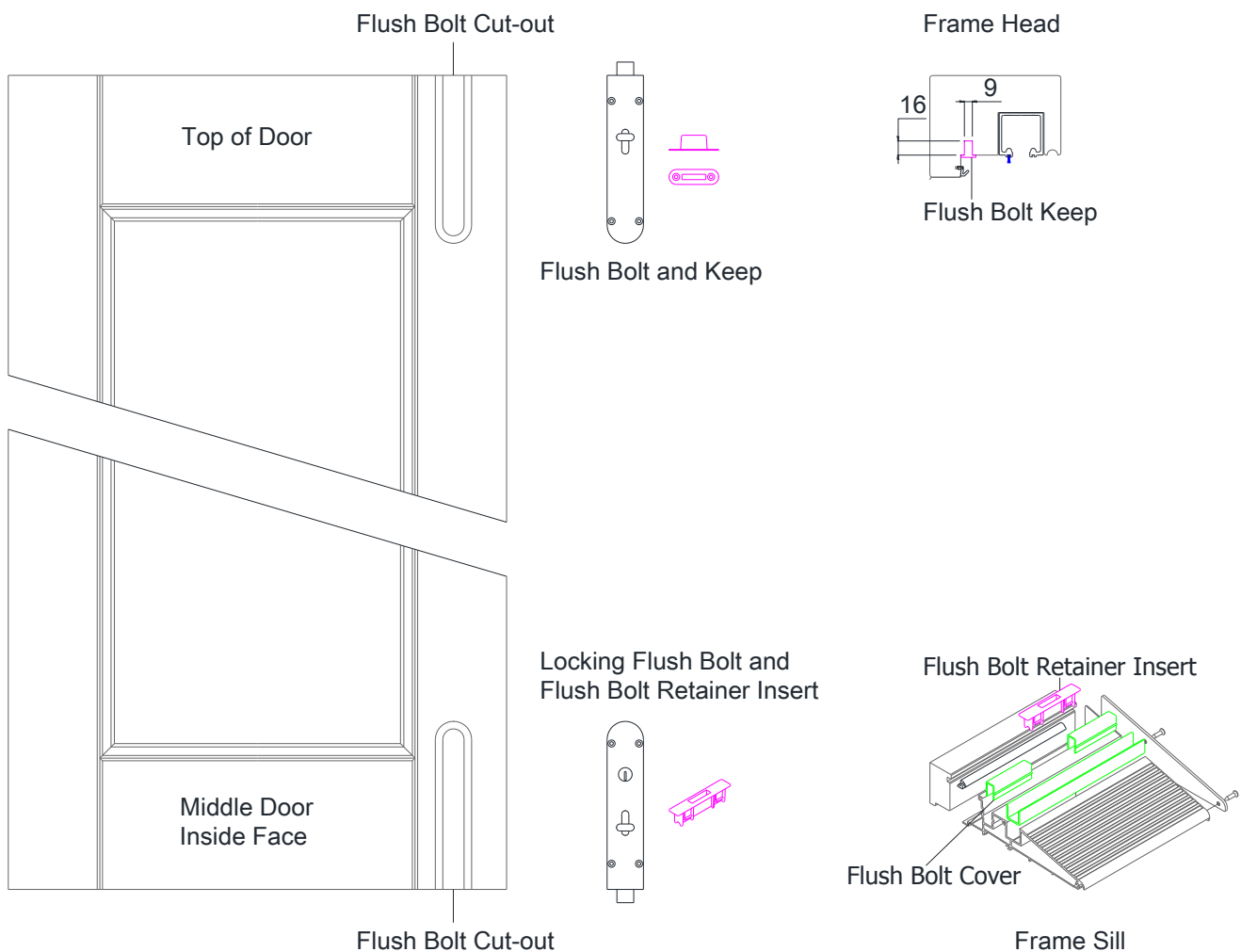

Fit the Lock, Keeps, Handles and Magnetic Catch

Fit the MPL Lock and Handles to the Locking Doors:

- Drill out MPL lock key-hole, handle spindle, and handle fixing screws through the locking door stile using the Handle Template at the end of these instructions. Note: The door latch may require to be turned around. If required, undo the two screws on the latch and spin it around and re-tighten the screws.
- Fit the MPL Lock with the screws provided, pre-drilling as necessary. Do not over-tighten the screws during fitting, e.g. by using a power drill driver with the incorrect torque setting. Excessive deflection of the MPL lock will impair its smooth function.
- Fix the handles to the locking door using the screws provided.
- With the door in the open position lift the handle upwards to ensure that the lock hooks operate properly: Check that the key also works and that the door can be locked and unlocked. Retract the lock hooks by moving the handle downwards.

Fit the One Piece Lock Keep and One Piece Keep Blank to the frame Jambs.

- The One Piece Keeps are located in the pre-machined grooves in the frame Jambs.
- Pre-drill the holes prior to securing the Keeps to the frame Jambs using the screws provided.
- Locate the One Piece Lock Keep so that the MPL Lock latch will engage against the Keep humps when door is closed.
- Fix the One Piece Blank Keep to the opposite Frame Jamb with the screws provided ensuring it is set at the same height as the One Piece Lock Keep.
- Close the doors, ensuring that the Flush Bolts are engaged: Lift the handle to ensure that the MPL Lock hooks engage smoothly into the One Piece Lock Keep: If necessary, adjust the Keep position until the MPL Lock hooks engage.
- If the MPL Lock latch is not engaging into the One Piece MPL Keep, adjustment is made by filing down the hump on the keep until the latch snaps into place.
- With all doors closed and the lock hooks engaged, turn the key to ensure that the door locks and unlocks.
- An optional Latch Plate is provided that can be countersunk into the frame Jamb to protect the finish from the MPL Lock latch during opening and closing the door.

The Optional Magnetic Catch is fixed between the bottom stiles of the Pivot and Middle Door Panel.

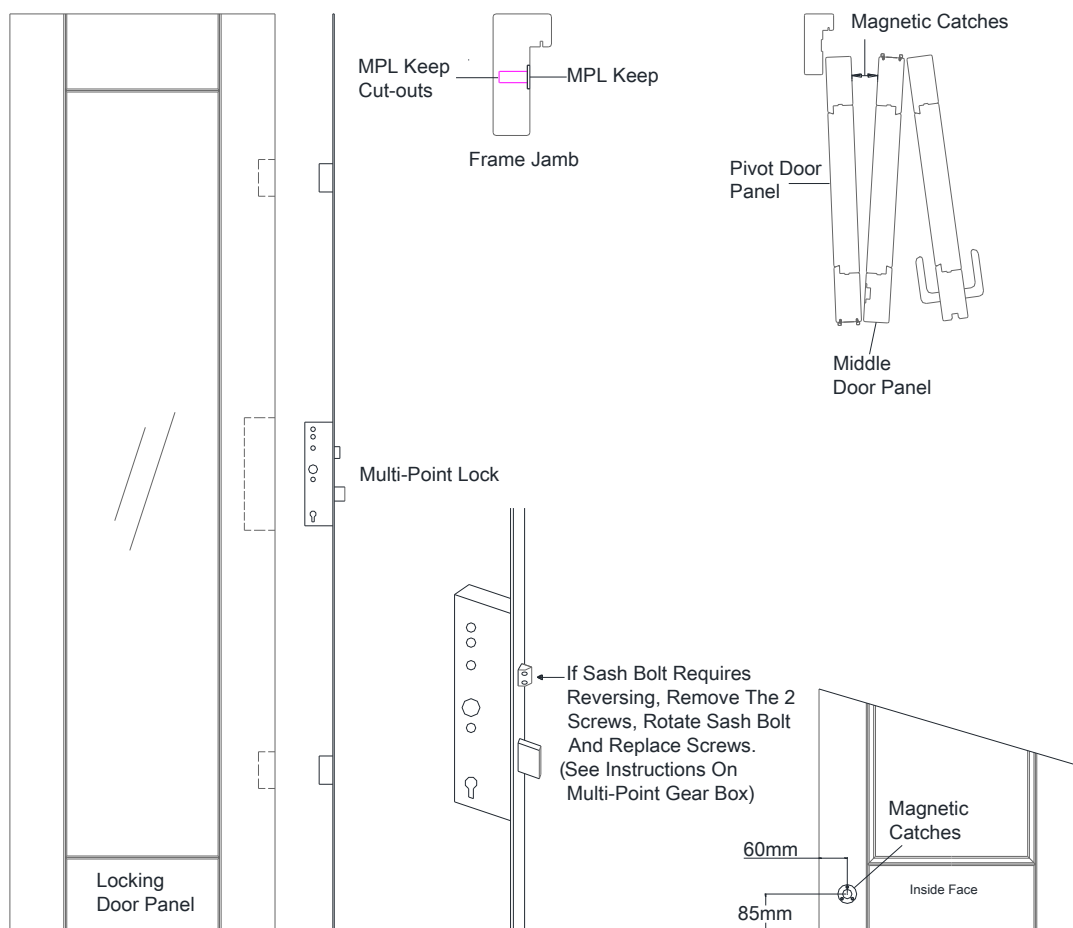

MAINTENANCE

Care and Protection by User

With proper care and attention, XL Joinery La Porte Vista Doorsets will give years of excellent service. To achieve this performance, the following should be observed:

- At least once per year all coatings should be washed with mild detergent and water to remove any surface pollution. Do not use a pressure washer for cleaning.
- All hinge mechanisms, locks and handles should be checked at least biannually for ease of operation and lubricated with light oil suitable for the purpose as required.
- Weatherseals should be cleaned at least once per year to remove any dirt or grime.
- Ensure the Aluminium Sill is clean and that there is no build up of dirt or other impediments.

Factory Painted & Stained Finish

The schedule specified in the table below should be followed to maintain the finish. No recoating should be required during this period provided the finish is not damaged. In rare instances, extremes of exposure may necessitate recoating at an earlier stage.

MAINTENANCE SCHEDULE			
CLIMATE			
	Moderate: Typically non-coastal areas at low altitude	Harsh: Exposed inland locations and areas within ½ a mile of the coast	Extreme: Exposed coastal sites and high altitude areas
Sheltered, e.g. protected by a porch, canopy or overhanging roof	Re-coat every 6-8 years	Re-coat every 6-7 years	Re-coat every 5-7 years
Part Sheltered, e.g. fitted behind exterior brickwork reveal	Re-coat every 6-8 years	Re-coat every 5-7 years	Re-coat every 3-5 years
Unsheltered, e.g. fully exposed face of the building	Re-coat every 5-7 years	Re-coat every 3-5 years	Re-coat every 3-5 years

The finish coat should be washed down with clean water to remove dust, insects and other contaminants, as these can form a base for algae and fungi growth. The coating surface should be inspected for mechanical damage and affected areas repaired accordingly. When carrying out any coating work, do not attempt to paint when the temperature is below 8 degrees Celsius or if the relative humidity exceeds 85%. The curing and performance of the coating may be impaired. Please refer to the coating manufacturers' instructions for further information

XL Joinery Ltd
Bradford Road, Batley, West Yorkshire,
England
WF17 8NE
Tel: 01924 350500
Fax: 01924 350525
www.xljoinery.co.uk

