

Tools Required

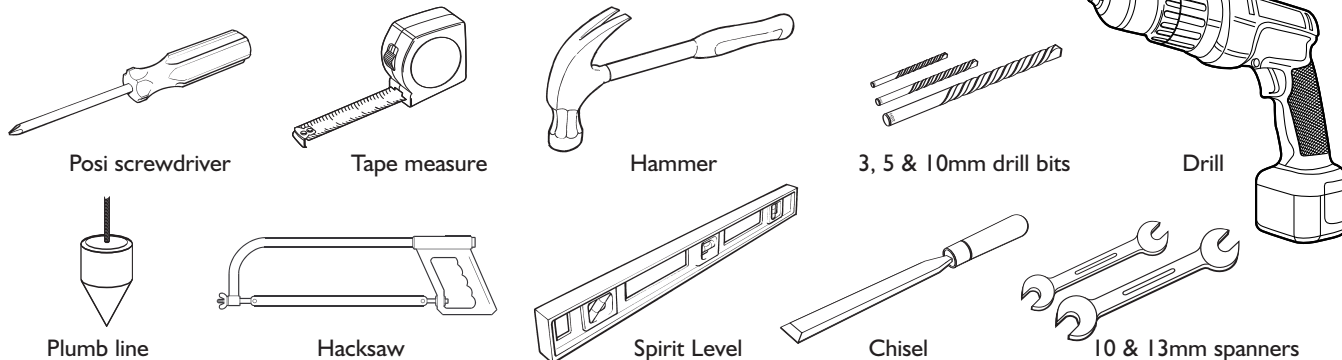

Cut the frame to size and assemble.

IMPORTANT

Please note: You can only assemble these door configurations by using the frame provided. Your warranty will be invalid if other alternatives are used. All loads are taken by the top track to ensure smooth, light operation and long life. Prior to installing this doorset, inspect for damage and do not proceed to fit if any noticeable damage or defect is evident. This doorset should be stored in a dry flat location before installation.

CAUTION



SAFETY: This product needs to be installed by a competent tradesperson with assistance. Two people are required to carry out the installation, as some components are heavy. The outer frame requires fixing to the supporting structure above the opening. The opening **MUST** be capable of carrying the load of the doorset in all conditions.

Check your structural opening for squareness, and that it is a minimum of those stated in the table.

| Number of leaves | 3 | 4 | 5 | 6 |
|--------------------|------|------|------|-----------|
| Dimension (Y)mm | 2130 | 2816 | 3502 | 4188 |
| Door Configuration | 3+0 | 3+1 | 5+0 | 3+3 & 5+1 |

Table of head lengths is as the part is supplied. These dimensions need to be trimmed to suit the doors you are using
See **Table A** for cutting details

Using a 5mm diameter drill bit, drill through the front head only to take 2 No.10 x 75mm screws

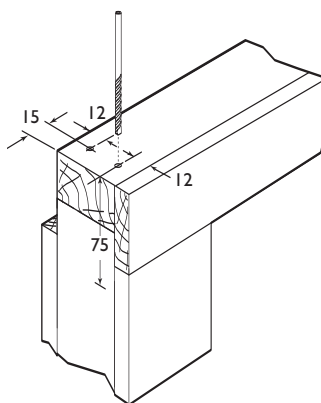

Back head - Screwed and glued to jamb and front head at the end of the installation

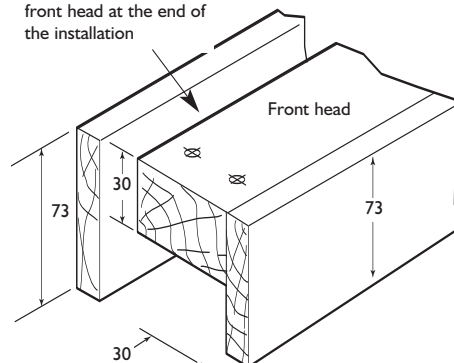

Table A - Structural opening sizes

| No. of Doors | 3 | 4 | 5 | 6 | 6 |
|---------------------|------|------|------|------|------|
| Door layout pattern | 3+0 | 3+1 | 5+0 | 3+3 | 5+1 |
| Door Width | 1'9" | 1681 | 2214 | 2747 | 3280 |
| | 2'0" | 1912 | 2522 | 3132 | 3742 |
| | 2'3" | 2140 | 2826 | 3512 | 4198 |

Cut down the head and track to suit the number of doors and size of doors - See **Table B** for cutting details

Table B - Head cut lengths

| No. of Doors | 3 | 4 | 5 | 6 | 6 |
|---------------------|------|------|------|------|------|
| Door layout pattern | 3+0 | 3+1 | 5+0 | 3+3 | 5+1 |
| Door Width | 1'9" | 1671 | 2204 | 2737 | 3270 |
| | 2'0" | 1902 | 2512 | 3122 | 3732 |
| | 2'3" | 2130 | 2816 | 3502 | 4188 |

Jamb height - 2048mm to suit 1981 high doors

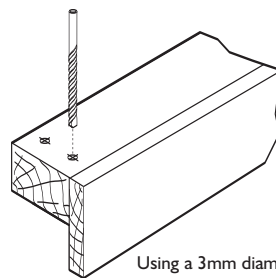

Using a 3mm diameter drill bit, drill 2 holes through the front head and into the jamb to an approximate depth of 75mm

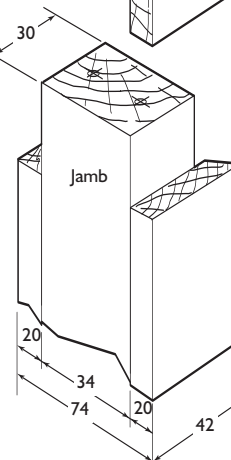

Secure the frame to the opening

Using the appropriate fixings attach the frame through both jambs at 450mm centres.

Important

Check the frame is accurately square and plumb. Do not proceed with the installation until the frame is accurately installed.

Once the frame is installed check the rebate dimensions are correct to your chosen configuration of doors from this table.

REBATE SIZES FOR ALL OPTIONS

| Door Width | 3 | 4 | 5 | 6 | 6 |
|------------|------|------|------|------|------|
| 3+0 | 3+0 | 3+1 | 5+0 | 3+3 | 5+1 |
| 1'9" | 1611 | 2144 | 2677 | 3210 | 3210 |
| 2'0" | 1842 | 2452 | 3062 | 3672 | 3672 |
| 2'3" | 2070 | 2756 | 3442 | 4128 | 4128 |

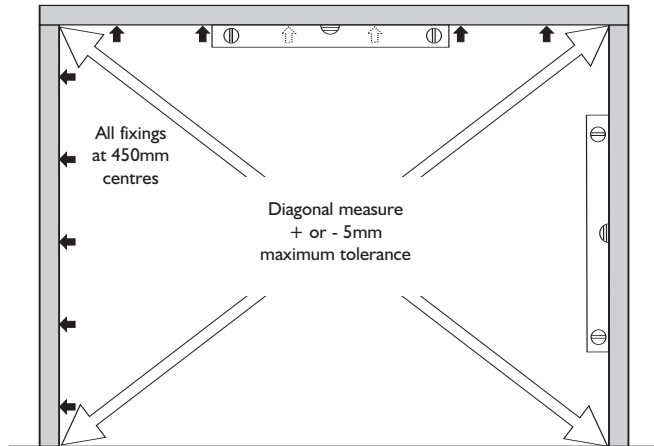

Contents of Kit

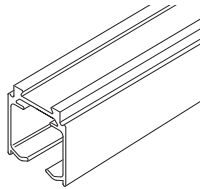

Track 280A

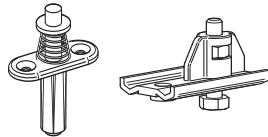

Top pivot 289T

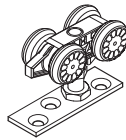

Apron plate and Hanger 283

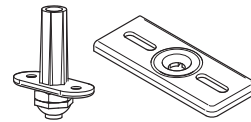

Bottom pivot 289B

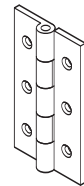

Hinge 282S

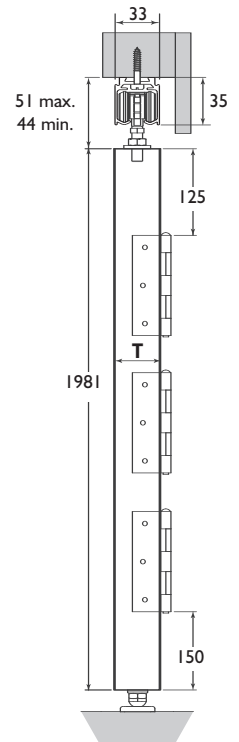
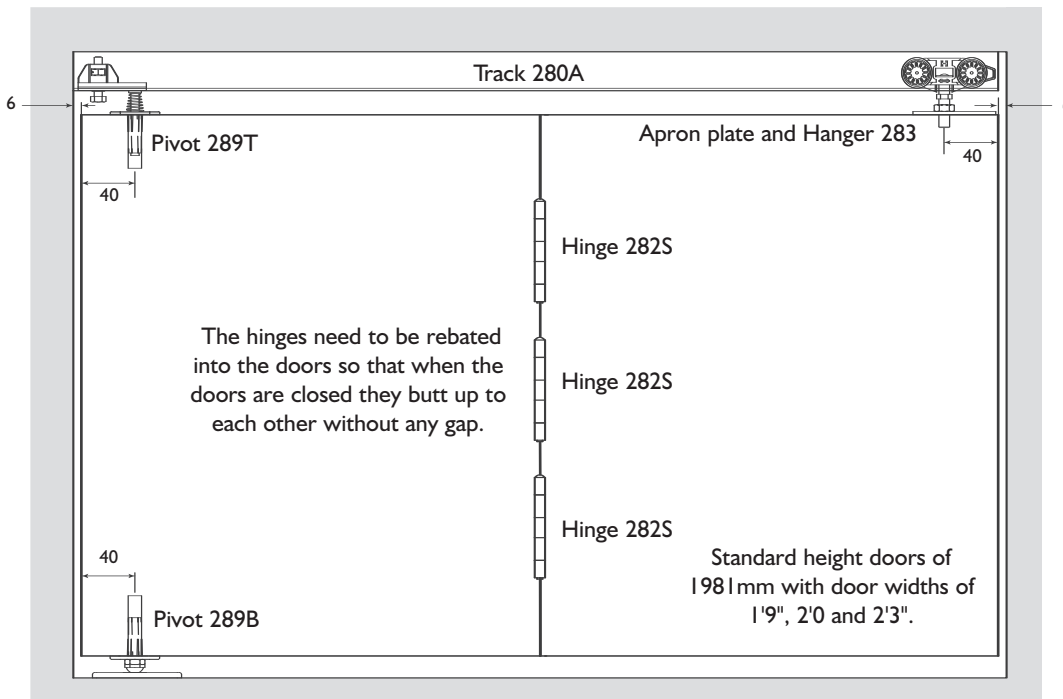

1. Position and secure pivot and hanger apron plates to suit the layout of the doors chosen.

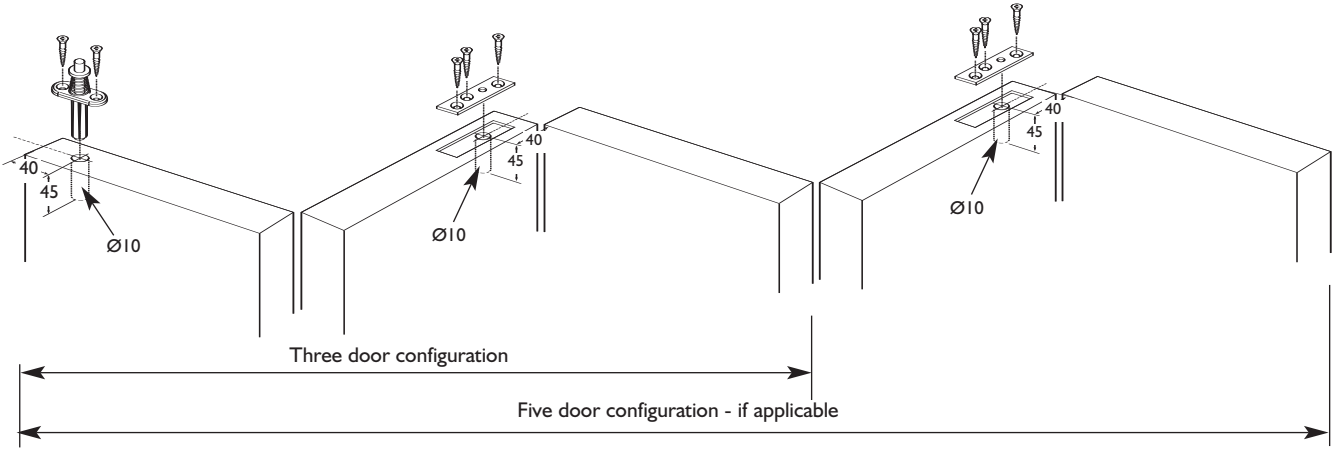

2. Fit bottom pivot to door.

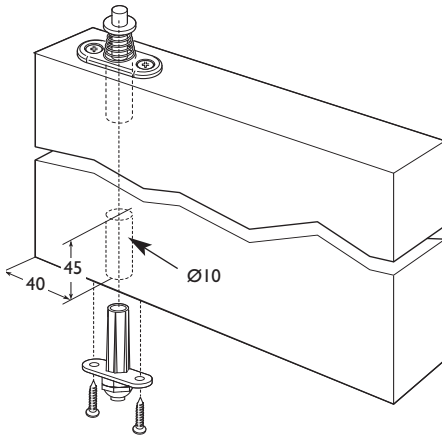

3. Fit hanger(s) to apron plate(s), to be securely fixed when adjustments have been made.

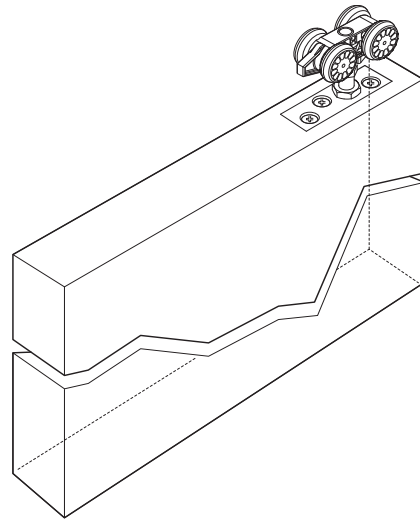

4. Position and secure hinges.

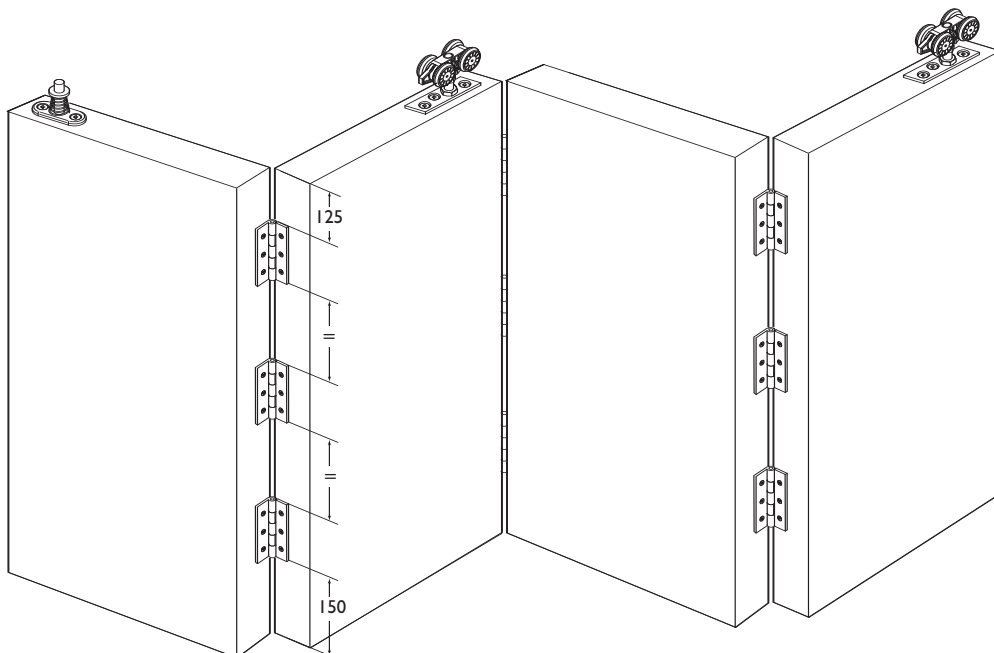

5. Fix track.

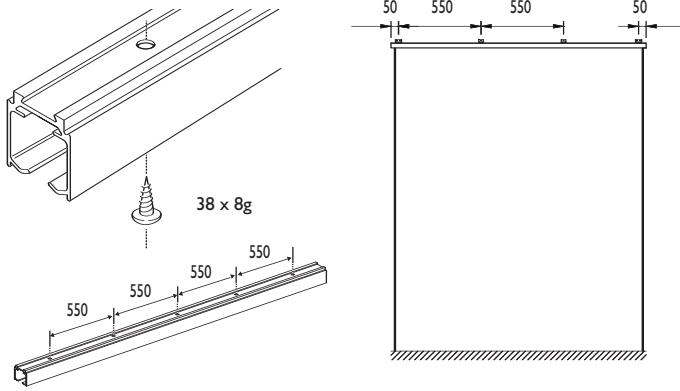

6. Position and secure top bearing plate

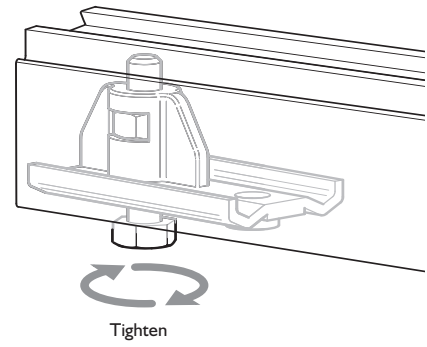

7. Locate and secure bottom pivot plate to floor.

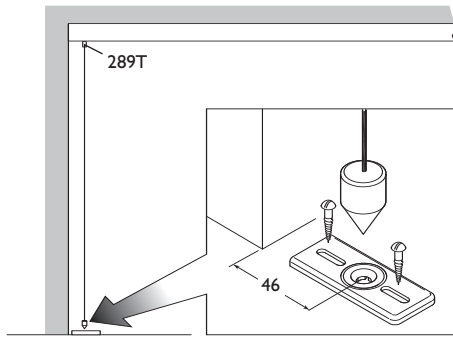

8. Slide doors onto track

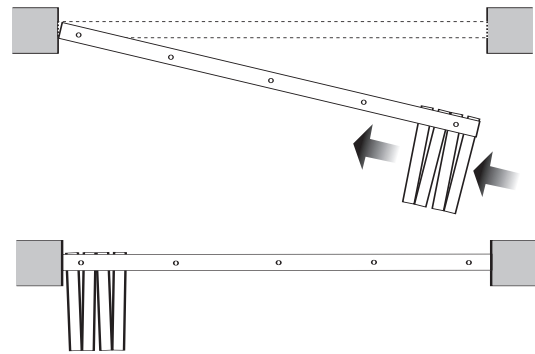

9. Adjust door height using 13mm spanner on pivot door and 10mm on hanger doors.

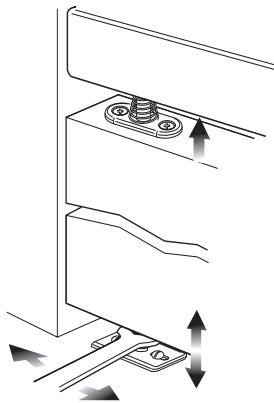

10. Align doors

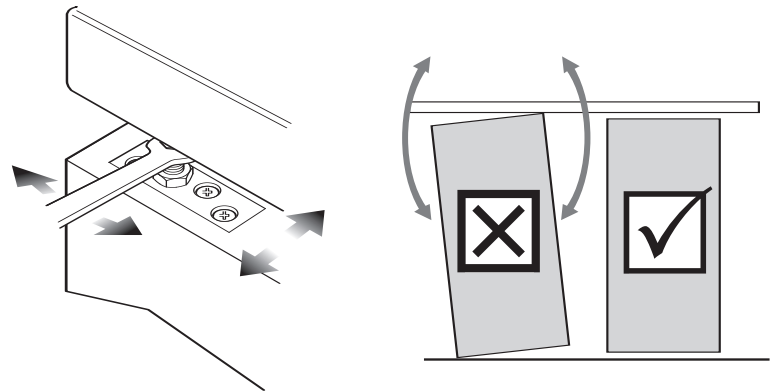

11. Door configuration options.

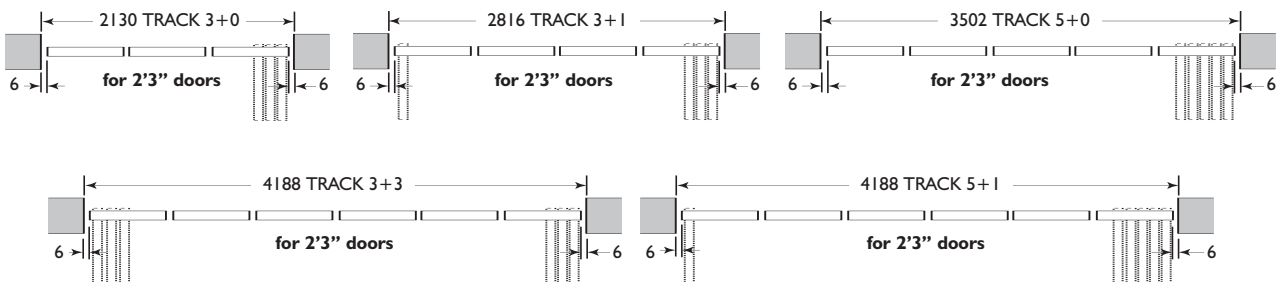

Refer to **Table B** for head and track length for 1'9" and 2'0" doors.